

Instruction sheet No. 3100
Revised 11-28-95

Copyright ©, 1986, 1995
by S&S Cycle, Inc.
All rights reserved. Printed in the U.S.A.

S&S[®] Cycle, Inc.

Box 215

Viola, Wisconsin 54664

Phone 608-627-1497

Fax 608-627-1488



Installation of S&S Sidewinder 3⁵/₈" Big Bore Cylinders for Evolution Sportster V² Engines - 1986 and Later

SAFE INSTALLATION AND OPERATION RULES:

Before installing your new S&S stroker kit it is your responsibility to read and follow the installation procedures in these instructions and follow the basic rules below for your personal safety.

- Gasoline is extremely flammable and explosive under certain conditions and toxic when breathed. Do not smoke. Perform installation in a well ventilated area away from open flames or sparks.
- If compressed air is used during installation, be particularly careful. Compressed air and particles dislodged by compressed air are harmful to eyes and body. Wear protective goggles, and always direct air stream away from body parts such as hands and eyes and other people near you.
- When using solvents, degreasers and other chemicals during cleaning and installation, read manufacturer's instruction label for proper use. Exposure of some chemicals to skin, eyes and/or other body parts may be harmful. Many items are flammable and present a fire hazard. Use in well ventilated area and wear protective clothing when using them to avoid personal injury.
- If motorcycle has been running, wait until engine and exhaust pipes have cooled down to avoid getting burned before performing any installation steps.
- Before performing any installation steps disconnect battery to eliminate potential sparks while working on electrical components.
- Read instructions thoroughly and carefully so all procedures are completely understood before performing any installation steps. Contact S&S with any questions you may have if any steps are unclear or any abnormalities occur during installation or operation of motorcycle.
- Consult an appropriate authorized H-D service manual for correct disassembly and reassembly procedures for any parts other than those outlined in these instructions.
- Use good judgement when performing installation and operating motorcycle. Good judgement begins with a clear head. Don't let alcohol, drugs or fatigue impair your judgement. Start installation when you are fresh.
- Be sure all federal, state and local laws are obeyed with the installation.
- Be sure all fuel lines, supply and overflow, are routed correctly and fuel line clamps are in place and tightened. Lines must not contact exhaust pipes or other extremely hot surfaces where they could melt or leak and catch fire.
- Before starting engine and riding motorcycle, be sure throttle opens and closes smoothly. Turn handlebars to left and test throttle. Then, turn bars to right and test throttle. To avoid possible loss of control of motorcycle and potential personal injury to yourself or others due to throttle sticking in open position, throttle must work smoothly and return to a fully closed position when hand is removed from throttle grip.
- Motorcycle exhaust fumes are toxic and poisonous and must not be breathed. Run motorcycle in a well ventilated area where fumes can dissipate

DISCLAIMER:

S&S parts are designed for high performance, off road, racing applications and are intended for the very experienced rider only. The installation of S&S parts may void or adversely effect your factory warranty. In addition such installation and use may violate certain federal, state, and local laws rules and ordinances as well as other laws when used on motor vehicles used on public highways, especially in states where pollution laws may apply. Always check federal, state, and local laws before modifying your motorcycle. It is the sole and exclusive responsibility of the user to determine the suitability of the product for his or her use, and the user shall assume all legal, personal injury risk and liability and all other obligations, duties, and risks associated therewith.

IMPORTANT NOTICE:

Statements in this instruction sheet preceded by the following words are of special significance:

WARNING

Means there is the possibility of injury to yourself or others.

CAUTION

Means there is the possibility of damage to the engine or motorcycle.

NOTE

Other information of particular importance has been placed in italic type.

S&S recommends you take special notice of these items.

WARRANTY:

All S&S parts are guaranteed to the original purchaser to be free of manufacturing defects in materials and workmanship for a period of six (6) months from the date of purchase. Merchandise that fails to conform to these conditions will be repaired or replaced at S&S's option if the parts are returned to us by the purchaser within the 6 month warranty period or within 10 days thereafter.

In the event warranty service is required, the original purchaser must call or write S&S immediately with the problem. Some problems can be rectified by a telephone call and need no further course of action.

A part that is suspect of being defective must not be replaced by a Dealer without prior authorization from S&S. If it is deemed necessary for S&S to make an evaluation to determine whether the part was defective, a return authorization number must be obtained from S&S. The parts must be packaged properly so as to not cause further damage and be returned prepaid to S&S with a copy of the original invoice of purchase and a detailed letter outlining the nature of the problem, how the part was used and the circumstances at the time of failure. If after an evaluation has been made by S&S and the part was found to be defective, repair, replacement or refund will be granted.

ADDITIONAL WARRANTY PROVISIONS:

- (1) S&S shall have no obligation in the event an S&S part is modified by any other person or organization.
- (2) S&S shall have no obligation if an S&S part becomes defective in whole or in part as a result of improper installation, improper maintenance, improper use, abnormal operation, or any other misuse or mistreatment of the S&S part.
- (3) S&S shall not be liable for any consequential or incidental damages resulting from the failure of an S&S part, the breach of any warranties, the failure to deliver, delay in delivery, delivery in non-conforming condition, or for any other breach of contract or duty between S&S and a customer.
- (4) S&S parts are designed exclusively for use in Harley-Davidson motorcycles. S&S shall have no warranty or liability obligation if an S&S part is used in any other application.

Introduction

Installation of an S&S Sportster V² 3⁵/₈" bore stroker Sidewinder Kit is comparatively easy and can be performed by any Harley-Davidson repair shop equipped to do complete engine overhauls.

NOTES

● To make installation of S&S Sidewinder series 3⁵/₈" bore kits easier, S&S has designed several Special Tools worth considering. They are:

Part #53-0002 - Connecting Rod Checking Pin - helps check piston alignment in cylinder bore.

Part #53-0020 - Degree Wheel Kit - used to check and set ignition timing and to check cam timing. This kit can also be used to check crankcase breather gear timing in big twin engines.

Part #53-0006, #53-0007 and #53-0008 - Crankcase Boring Fixture and V² Crankcase Boring Spacers - adapts most boring bars so crankcases can be bored to fit larger diameter spigots on big bore cylinders. Enables qualified operator to bore cases in about an hour after initial setup. Can also be used to bore pre-Evolution style Big Twin heads when installing big bore cylinders.

Part #53-0003 100ml Buret - used to measure combustion chamber volume (cc heads) to calculate compression ratio.

● S&S pinion shafts for Evolution Sportsters are the 1987 style splined shaft because this design is stronger than the later style stock straight shaft and key. As a result, the engine builder must use a 1986-1987 style pinion gear (H-D #24055-86 through #24061-86) and oil pump drive gear H-D #26318-75. Stock Torrington style pinion main bearing in 1986 crankcases must be replaced with 1987 style race and later steel caged roller bearing. **See Steps 6 and 10.**

● Due to increased cylinder length, S&S Sidewinder kits of 96" and larger displacement require that stock cylinder studs be replaced with Big Twin style cylinder studs.

Read instructions thoroughly before starting work. When they are completely understood proceed with installation. It is strongly recommended that the engine builder also obtain a copy of an H-D service manual of the same year as the engine being built.

Installation Steps:

1. Clearance Frame*
2. Crankcase Alignment
3. Cylinder Mounting Studs (96" and larger engines only)
4. Bore Crankcases
5. Modify Crankcases for Oil Returning from Heads
6. Convert Pinion Main Bearing To 1987 and Later Style (1986 crankcases only)
7. Connecting Rod Preparation (79" engines only)
8. Lower End Assembly
9. Crankcase and Piston Skirt Clearancing
10. Connecting Rod Alignment*
11. Cylinder Head Preparation
12. Piston to Head and Piston to Valve Clearancing
13. Final Assembly and Engine Installation
14. Engine Break-In Procedure
15. Performance Notes

*NOTE - S&S recommends that engine builder consider performing some steps during initial engine removal and disassembly. Checking clearance between stock engine and frame will allow an accurate estimate of amount and location of clearancing required after kit is installed. While entire flywheel and rod assembly may be replaced, it is sometimes helpful to check original parts combination and note problems that can be corrected more easily before engine is reassembled.

Installation

1. Clearance Frame

NOTE - Piston stability in cylinder bore is improved by using pistons with the longest possible skirts. In order to provide a performance engine with the best possible engine life, S&S increases the cylinder length when the stroke is increased, rather than decreasing the length of the piston. Frame fit, stock rocker cover to frame tubes and/or rocker cover to gas tank clearances in taller than stock engines must be checked and corrected if needed. It is recommended that frame clearance be measured before stock engine is removed from frame. The 89" Sidewinder kit is the largest engine that will fit in a stock frame without major frame modifications.

To check and clearance frame, perform following steps:

- A. Before stock engine is removed from frame, measure clearance between rocker boxes and frame. Tightest spot is normally above and behind rear head.

Kit Part Number	Displacement	Stroke	Cylinder Length	Cylinder Length Compared to Stock
91-3002	79"	3-13/16"	4.650"	Stock Length
91-3204 91-3206	89"	4-15/16"	5.087"	+.437"
91-3304 91-3306	96"	4-5/8"	5.565"	+.915"
91-3504 91-3506	103"	5"	5.750"	+1.100"

Figure 1

- B. Refer to chart in **Figure 1** to determine increase over stock engine height for the kit to be installed. S&S recommends .100" minimum clearance between engine and frame. If increased cylinder height of Sidewinder kit will not leave sufficient room, clearancing will be required. S&S V² XL style cylinder heads are .062" taller than stock, so additional clearance will be required if S&S heads are to be used.

NOTE - S&S recommends there be .100" minimum clearance between engine and frame. Up to .060" or .070" may be ground from rocker box cover in some areas for clearance. If cover is ground, be careful not to break through since covers are very thin.

CAUTION - Excessive material removed from rocker cover may damage cover causing oil leaks.

WARNING - Removing material from welds or frame tube may cause structural damage and possible failure resulting in personal injury or death. If frame must be modified, work should be done by a professional frame shop.

- C. After crankcases have been bored in **Step 4**, mock up engine using Sidewinder cylinders. Place mocked up engine in frame and determine if additional clearancing will be needed to provide recommended .100" space between engine and frame.

2. Crankcase Alignment

NOTE - Some H-D crankcase base gasket surfaces on which cylinders are positioned do not align properly. This usually occurs when crankcase halves used are from different crankcase assemblies and were not paired and machined together during manufacture. It is recommended that crankcases be checked for misalignment even if crankcase halves are correctly matched to prevent potential oil leaks and other mechanical problems.

CAUTION - Mismatched gasket surfaces due to improperly aligned crankcase halves may cause oil leaks.

- Clean cases thoroughly and assemble both halves without flywheels. Tighten all case bolts as in final assembly.
- Place straight edge ruler across base gasket surface. **See Picture 1.**
- If crankcase halves are correctly aligned, proceed to **Step 3**. If any misalignment exists go to **Step D** in this section.
- Remove cylinder studs and place masking tape over cam and mainshaft bearings to keep chips out. Consult H-D service manual for proper cylinder stud removal and installation procedures.



Picture 1

CAUTION - Be careful when removing studs so as not to damage threads in cases. If heat is applied to case around stud to help loosen threads, do not allow crankcase temperature to exceed 375° F as this may destroy heat treatment of crankcase material.

- Place cases squarely in mill. Base gasket surface must be square with center line of crankshaft and 45° from opposite cylinder base gasket surface. Machine gasket surface taking minimum necessary to clean surface. Repeat for other cylinder.
- Reinstall cylinder studs. For engines under 96" (4 5/8" stroke) reinstall V² Sportster style studs. For engines of 96" or larger install late Big Twin style studs. (**See Step 3**) Consult H-D service manual for proper stud installation procedure.

3. Cylinder Mounting Studs 96" Engines and Larger only

NOTE - S&S Sidewinder kits for Evolution Sportsters of 96" (4 5/8" stroke) or greater require the use of Big Twin style cylinder studs. This is due to the increased cylinder length in these kits.

- Remove stock cylinder studs if this has not been done in **Step 2**. Consult H-D service manual for proper stud removal procedures.

CAUTION - Be careful when removing studs so as not to damage threads in cases. If stud does not come out easily, carefully heat case around stud as heat may help loosen threads. Do not allow crankcase temperature to exceed 375° F, as this may destroy heat treatment of crankcase material.

- Install late style Big Twin V² male type studs, S&S #31-2321 or #31-2323, or H-D part #16837-85C. Consult H-D service manual for proper installation procedures.

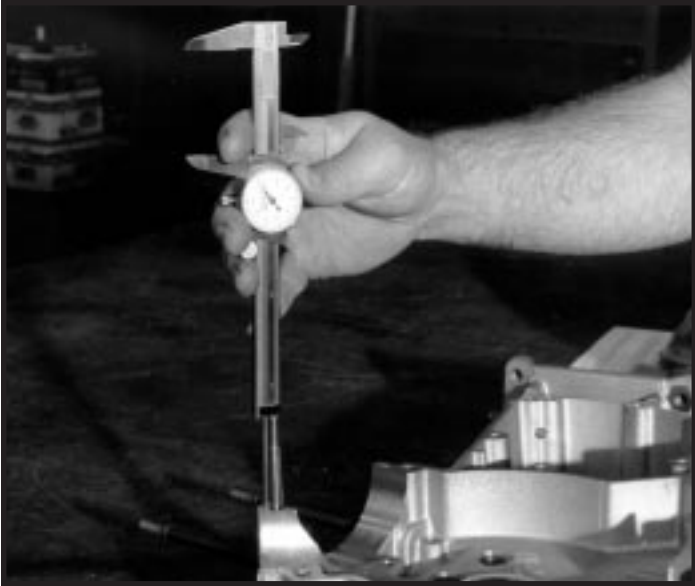

Picture 2

4. Bore Crankcases

NOTE - Boring cylinder spigot holes in cases to accommodate big bore cylinders will machine a notch on center case bolt. This bolt must be replaced with a special stud which is installed into the top crankcase bolt hole in the cam side case half.

Perform following procedure to bore crankcases:

- A. In 1986-1990, four speed cases, the center crankcase bolt must be replaced by S&S stud #31-2046. In 1991 and later, 5 speed cases, the center crankcase bolt must be replaced by S&S stud #31-2047. The stud will be installed in the threaded hole in the camside crankcase half that the stock center crankcase bolt normally screws into.
1. Before final installation of stud, screw stud into hole to make sure installed height is correct. **See Picture 2.** Stud should extend 2.570" - 2.630" from crankcase to top of stud for 1986-1990 crankcases, and 2.270" - 2.330" from



Picture 3

crankcase to top of stud for 1991 and later crankcases. If driveside case is set in place, stud should extend far enough that there is full thread engagement with 12 point nut #31-5024 when washer is in place. **See Picture 3.**

2. If stud can not be screwed in far enough to obtain specified stud height, hole must be drilled and tapped deeper. It is recommended that this drilling operation be done on a milling machine or drill press to avoid destroying existing threads.
 3. If stud can be installed to correct height, clean stud and threaded hole with lacquer thinner and install stud to correct height using red Loctite or other permanent thread locking compound.
- B. Clean cases thoroughly and assemble using all case bolts. Tighten all case bolts as in final assembly.
 - C. Place masking tape over both ends of camshaft and mainshaft bearings to keep chips out.
 - D. Bolt boring plate to bench or stand leaving squared end of plate protrude over edge approximately 7".
 - E. Using 4 $\frac{3}{8}$ -16 thread nuts, bolt cases to plate using all four studs. Boring spacer, Part #53-0007, is used to space cases using stock Sportster V² studs. If Sportster studs have been replaced with late, male style Big Twin studs, use both #53-0007 and #53-0008 spacers to space cases away from boring fixture. **See Picture 4.**

NOTE - Be careful not to damage studs. Do not lift cases by studs and avoid knocking, scratching or denting studs.

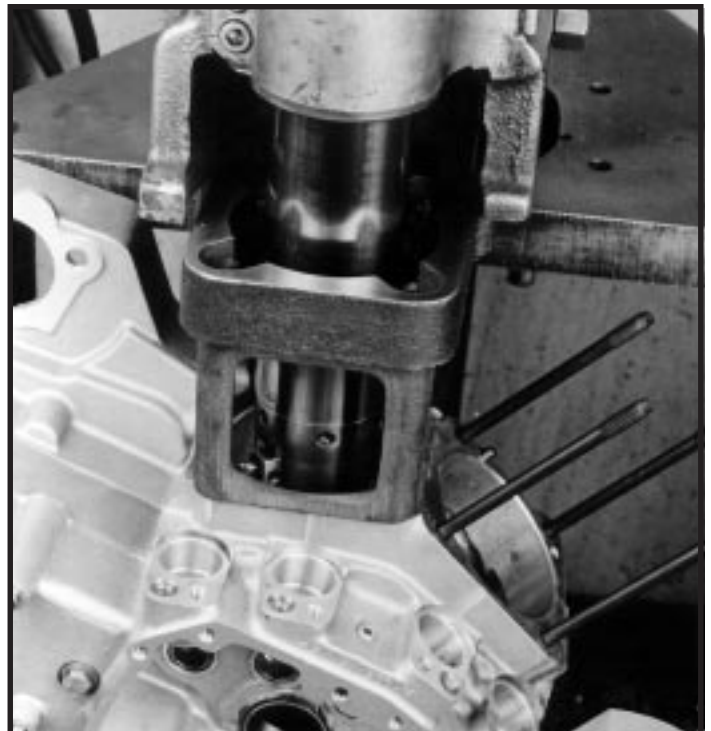

Picture 4

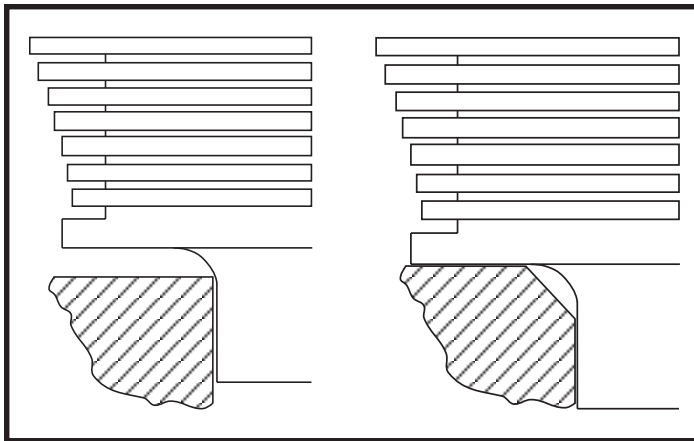

Figure 2

CAUTION - Damaged studs may cause stress risers which can lead to stud failure and possible damage to engine components.

- F. Center boring bar head in cylinder spigot bore in crankcases, not hole in plate. Refer to manufacturer's instructions supplied with boring bar for correct procedure.
- G. Bore hole to diameter of 3.878" to 3.880" by $1\frac{1}{8}$ " deep. Measure depth perpendicular from cylinder base gasket surface.

NOTE - We normally take three cuts to bore cases, 3.800" diameter, 3.850" and final size 3.879". If you machine into boring plate on final cut, this is of no consequence since hole in plate is never used as machining reference point.

- H. Repeat steps E to G for other spigot bore.
- I. Deburr and remove any "nubs" or protrusions which could accidentally break off. Break the corner on outside of spigot holes with a deburring tool. This insures that cylinder will not "hang up" during installation causing oil leaks due to inadequate gasket compression. **Figure 2** shows an exaggerated view.

5. Modify Crankcases for Oil Returning from Heads

NOTE - Oil return passageways in V² Sidewinder cylinders are moved out slightly compared with stock oil return holes to accommodate 3 $\frac{5}{8}$ " bore. This creates misalignment between cylinder oil return passage and crankcase oil return passage.

To modify cases and return oil properly, perform following steps:

- A. Place cylinder base gasket on cases and note amount and direction of return hole mismatch.
- B. Chamfer edge of hole accordingly at minimum of 45° angle to insure adequate flow. **See Pictures 5 and 6.**

6. Convert Pinion Main Bearing To 1987 & Later Style (1986 crankcases only)

- A. Remove stock Torrington style pinion needle bearing assembly. Follow procedures outlined in 1986 H-D service manual for removal.
- B. Install 1987 and later style pinion bearing race H-D #8881. Follow procedures outlined in 1987 and later H-D service manual.
- C. Lap bearing race and fit bearings per procedures outlined in 1987 and later H-D service manual.

7. Connecting Rod Preparation (79" kits only)

NOTE - If S&S connecting rods are used, follow instructions that accompany rods since rod preparation below has already been done. Stock rods can not be used with Sidewinder kits larger than 79". Longer than stock S&S connecting rods will be provided with all kits larger than 79".

79" kit #91-3002 only - If S&S rods are not used, perform following steps:

- A. To insure adequate oil on sides of rods and matching thrust surfaces of flywheels, S&S



Picture 5



Picture 6

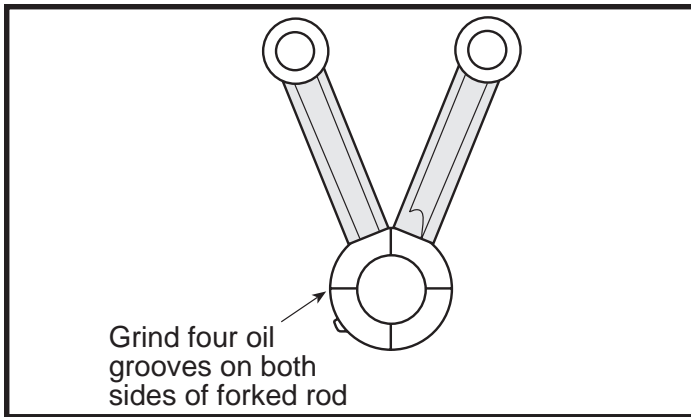

Figure 3

recommends that four grooves be ground on each side of both front and rear connecting rods. **See Figure 3.** Make these grooves .020" to .030" deep and .030" to .040" wide and should be ground 90° from each other. After making grooves, remove all sharp edges and burrs with emery cloth.

- B. Thoroughly clean all parts to remove dirt, filings, etc.

CAUTION - Burrs, dirt, filings, etc. left on connecting rod components may circulate in oil damaging other parts possibly causing engine failure.

8. Lower End Assembly (All)

NOTES

● All current production S&S Evolution Sportster style flywheels are made from closed die, heat treated, steel forgings. They do not have connecting rod thrust washers like earlier S&S or stock flywheels, because present flywheel material is harder than thrust washers previously used.

● S&S Sportster V² style flywheels come with three timing marks, "F", "R" and "TF". The "F" mark stands for front cylinder 30° before top dead center (TDC). The "R" mark is rear cylinder 30° before TDC, The "TF" mark is TDC front cylinder. When "F" or "R" mark is placed in center of timing hole it means that cylinder is timed at 30° before TDC. We recommend that "big inch" Sportster engines be timed at 30-32° before TDC rather than the stock 40° before TDC. See Performance Notes, "Ignition Timing".

● Usually S&S flywheels are balanced before leaving our facility. Some customers prefer to do their own balancing or to have another balancing shop do the work for them. This is acceptable in most cases. However, we have had some bad experiences with dynamically balanced flywheels that have forced us to void our guarantee if flywheels have been balanced in this fashion.

CAUTION - Flywheels assembled improperly prior to being dynamically balanced may sustain irreversible damage to mainshaft and crankpin tapers during actual balancing. S&S voids its guarantee if flywheels have been balanced in this fashion.

● Many problems in assembling and truing flywheels can be prevented by careful inspection of all parts used in the assembly.

● Cleaning parts prior to and during assembly and keeping parts clean after final assembly are imperative to minimize contaminants that may circulate in oil and shorten engine life. Many parts can be cleaned with soap and water first. Then, reclean all internal parts and gasket mating surfaces using high quality solvent that does not leave any harmful residues. Be sure to read and follow manufacturer's instruction label before use. Use drills and compressed air to clean all oil passageways of dirt, filings, etc. whenever possible. During actual final assembly, recoat all internal parts with high quality engine oil or assembly lube such as S&S #51-9000.

CAUTION - Manufacturing chips, dirt and/or other contaminants circulating in engine oil may possibly damage engine components resulting in shorter engine life and possible engine failure.

WARNINGS

● Some solvents, degreasers, gasoline and other chemicals are harmful to skin, eyes and other body parts. Many items are flammable and present a fire hazard. Read manufacturer's instruction label for proper use. Use in well ventilated area and wear protective clothing when using them to avoid personal injury.

● Compressed air and particles dislodged by compressed air are harmful to eyes and body. Wear protective goggles when using compressed air and always direct air stream away from body parts such as hands and eyes. Never direct compressed air toward other people.

Perform following steps when assembling flywheels:

- A. Thoroughly clean all parts to be used. This includes mainshafts, main bearings, connecting rods, rod bearings, keys and flywheels including tapers and key ways.

CAUTION - Burrs, dirt, filings, etc. left on flywheel assembly parts may circulate in oil damaging other parts possibly causing engine failure.

- B. Inspect key ways and oil holes in flywheels for burrs and remove if necessary.

NOTE - S&S does not recommend lapping tapers to remove burrs. This practice tends to distort the taper by removing material unevenly around the circumference. This makes flywheels difficult if not impossible to true. In addition the lapping process work hardens the surface of the taper. This hard surface makes it very difficult to pull shaft or crankpin into taper. If crankpin and shafts are not pulled fully into flywheel tapers, excessive rod side play and assembly width may result. Lapped flywheel tapers are also very difficult to resurface if repairs are ever needed.



Picture 7

CAUTION - S&S warranty is void if flywheel tapers are lapped.

- C. Check keys in grooves of shafts. Key should be light hand press fit in groove. If key is too tight in groove, sand side key with fine sand paper on a metal plate or other flat surface. Do not hammer key into groove.

CAUTION - Hammering tight key into groove may result in irreparable damage to shaft.

- D. With key in shaft, insert into respective tapered hole in flywheel and check to see that key does not bottom in groove. If key bottoms out, file flat side of key, not rounded side, until shaft with key in place fits in flywheel without bottoming out. Check crankpin and crankpin key also.
- E. Reclean mainshaft tapers, crankpin and flywheel tapers with lacquer thinner.
- F. Assemble mainshafts in respective flywheels. Coat taper and threads of each shaft with green Loctite during assembly. Install crankpin in camside flywheel using Loctite also. Tighten crankpin nuts to 290-310 Ft. Lb. Tighten pinion and sprocket shaft nuts to 340-360 Ft. Lb.
- G. After camside flywheel, pinion shaft and crankpin are assembled, blow air through pinion shaft oil feed hole to check for blockage or misalignment of oil feed passages.

CAUTION - Partially or completely blocked oil feed passageways may cause irreversible damage to connecting rod bearings and other engine components.

- H. Measure width of female rod on crankpin end. **See Picture 7.** Measurement should be 1.481" to 1.483".
- I. A pre-assembly connecting rod side play check should be done before final assembly to determine if connecting rod side play will fall within the specified .015"-.035" range when crankpin nuts



Picture 8

are final tightened. Assemble left and right flywheels on crankpin without rods. Moderately snug crankpin nuts. Do not worry about flywheels being true. Measure distance between connecting rod thrust pads on flywheels. **See Picture 8.** Rod side play will be reduced by about .015" when crankpin nut is final tightened. Therefore, distance between flywheel thrust pads as measured in this check must be .030"-.050" greater than female rod width measured in **Step H**. For example, if female rod measures 1.482", the distance between flywheel pads must be 1.512"-1.532". If difference between pad to pad distance and female rod width is less than .030", female rod must be surface ground on sides to provide more clearance. Take equal amounts off each side if more than .010" is to be removed. If more than .050" must be removed from female rod width or if difference between pad to pad distance and female rod width is greater than .050" a different crankpin should be tried. If there is too little or too much connecting rod side play, and different crankpins do not correct problem, contact S&S.

NOTE - S&S recommended rod side play is .015" to .035". If material is removed from sides of female rod, overall width of bearing cages must be reduced so bearings and cages are free to float with rods without contacting flywheel thrust pads. Bearing cage side clearance of .008" to .020" less than rod width is recommended.

CAUTIONS

- Incorrect connecting rod side play may cause excessive rod side thrusting and potential damage to rods, flywheels and other engine components.
- Connecting rod bearing and cage assemblies that are wider than female rod may become damaged upon contact with flywheel thrust pads. Abrasive particles from damaged rod bearings may circulate in oil and cause damage to other engine parts.

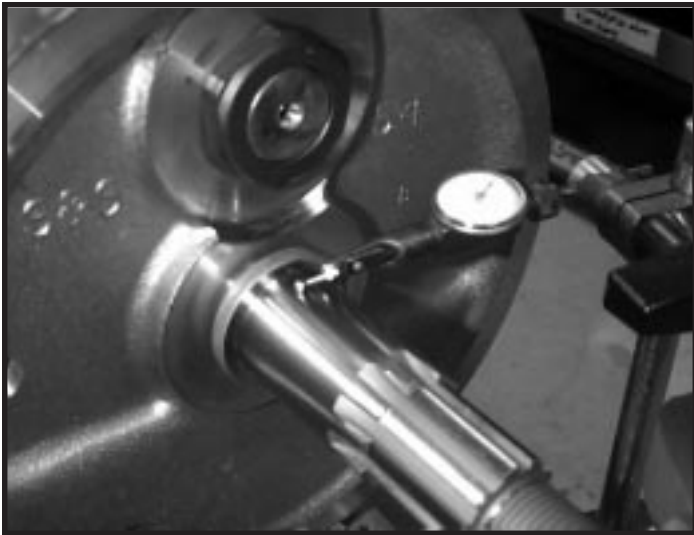

Picture 9

- J. Finish assembling flywheels and rods.
- K. Check flywheel assembly for run out by placing ends of mainshafts between centers. Place dial indicators on bearing surfaces of mainshafts. **See Picture 9.** True wheels as needed. S&S trues flywheel assemblies to .0005" or less runout on either mainshaft bearing surface. However H-D factory specs call for .001" runout and this is acceptable.

NOTES

- When truing flywheels, runout measurements must be taken on mainshaft bearing surfaces. Do not take measurements on flywheel rims. Flywheel rim will show runout that is not a valid indication of mainshaft concentricity.
- Do not install flywheels and final assemble crankcases until clearances are checked in **Step 9.**

9. Crankcase and Piston Skirt Clearancing (All)

NOTE - Many of the clearancing operations described in this section can be done simultaneously as the same set-



Picture 10

ups are used. Please read this entire section before beginning work.

CAUTION - Insufficient clearance between connecting rods and crankcases, pistons and flywheels, and between the two pistons will cause contact and damage to components.

- A. Connecting Rod Clearance - Front and rear of flywheel cavity inside crankcases and cylinder spigots must be clearanced for connecting rods. **See Pictures 10 and 11.** Procedure to check these points is performed as follows:
 1. Mock up flywheel assembly in right crankcase half with bearings, etc. in place.
 2. Assemble pistons without rings on their proper connecting rods, and place connecting rods on crankpin. Installation of wristpin clips is not necessary.

NOTE - All S&S Sidewinder kits have piston to piston clearance notch cut in the front skirt of rear piston. Rear piston must be installed with notch toward the center of engine.

3. Install both cylinders and secure each with one head bolt.
4. Rotate flywheel until rods contact areas to be clearanced. Note angle that must be filed.
5. Disassemble cylinder and connecting rods and file crankcase and cylinder spigot for clearance. **See Picture 12.**

NOTE - A minimum of .060" clearance is required between connecting rods and crankcase and cylinder spigots.

6. Reassemble and check clearance.
7. Mark and grind other crankcase half to identical clearance.

- B. Piston Clearance - Piston clearances must be checked to avoid piston to piston contact and piston to flywheel contact. **See Pictures 13 and 14.**

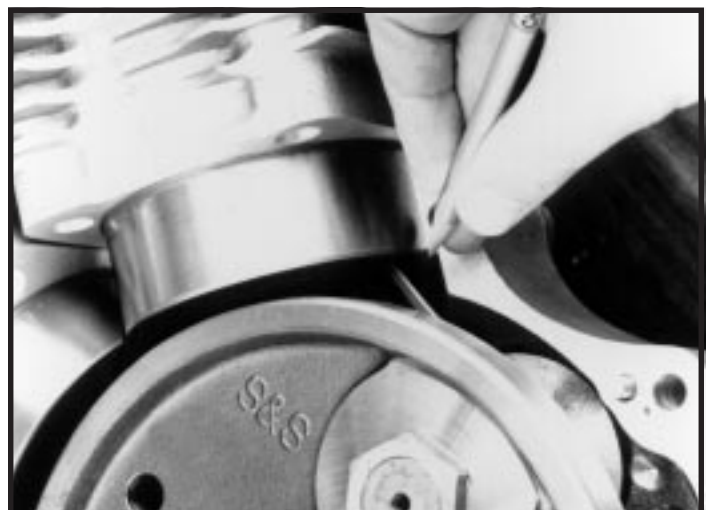

Picture 11



Picture 12

NOTE - Pistons are normally preclearanced in S&S kits, but good engine building practice demands that all clearances be checked during assembly. In the event that additional clearancing must be done, weight of material removed from pistons generally is too small to significantly affect flywheel balance.

1. Piston to Piston Clearance
 - a. Perform **Steps 1 through 3** in "Connecting Rod Clearance" above.
 - b. Rotate flywheel to position where pistons are closest to each other. This is at the bottom of the stroke. **See Picture 13.**
 - c. Check clearance between pistons.

NOTE - A minimum of .060" clearance is required between piston skirts at the bottom of the stroke.

- d. If clearance is not sufficient, disassemble cylinders and pistons, and carefully file notch in front skirt of rear piston until clearance is obtained.

NOTE - The rear skirt of the piston is the primary thrust face, and carries the greatest load during engine



Picture 13

operation. For this reason, piston to piston clearancing is done on the front skirt of the rear piston in order to leave the rear skirts of both pistons as long as possible.

- e. Reassemble and recheck clearance.
2. Piston to Flywheel Clearance
 - a. Perform **Steps 1 through 3** in "Connecting Rod Clearance" above.
 - b. Rotate flywheel to position where front piston is closest to flywheel. This is at the bottom of the stroke. **See Picture 14.**
 - c. Check clearance between piston and flywheel.

NOTE - A minimum of .060" clearance is required between piston skirts and flywheels at the bottom of stroke where pistons are closest to flywheels.

- d. If clearance is not sufficient, disassemble cylinder and piston, and carefully file piston skirt until clearance is obtained. Skirt of piston may also be fly cut on a milling machine to provide clearance.
- e. Reassemble and recheck clearance.
- f. Repeat procedure for rear piston.

10. Connecting Rod Alignment (All)

NOTES

- *The purpose of this procedure is to correct for machining tolerance discrepancies in components which may lead to pistons not running true in cylinder bores. While rods may be straight and true, it is sometimes necessary, to bend them to correct for these machining discrepancies. Do not bend rod by using tool in wristpin hole as this method may distort wristpin bushing. We also feel that using a piston in lieu of a checking pin may prove inaccurate due to variations in lengths of piston skirts from one side of piston to the other.*
- *All engines should be checked upon disassembly for incorrect piston alignment. This applies to those which are receiving new pistons as well as those being*



Picture 14

completely rebuilt. Observe pistons for wear spots on sides above top compression ring. If one side near wristpin is worn clean while side opposite is carboned up, then piston was not running straight and true in cylinder bore. Piston will also generally show diagonal wear pattern on thrust faces of skirts and possibly signs of connecting rod to wristpin boss contact inside piston.

● We feel that not enough emphasis is given to checking piston alignment in cylinder bore. Proper piston alignment means connecting rods will thrust to sides less minimizing added stress on pistons, rings, rod bearings and other related parts.

● S&S Rod Checking Pin, part #53-0002, was designed to help perform this procedure. It may also be necessary, to fabricate a rod bending tool as illustrated in **Figure 4**.

CAUTION - Pistons which do not run true in cylinder bores may cause excessive connecting rod side thrusting. This in turn may lead to premature ring, piston, connecting rod and rod bearing wear and eventual failure of these parts.

- A. Install flywheels in crankcases per H-D factory procedures. After flywheel assembly is installed in crankcases, rods must be checked for straightness.

NOTE - Pinion Shafts included in all S&S V² XL flywheels kits and assemblies are of the 1987 type. This means that 1986 crankcases must be converted to use the 1987 and later style caged roller pinion main bearing assembly, and that 1986 -1987 style pinion gear and oil pump drive gears must be used in 1988 and later engines. See Step 6.

B. Checking Pin Procedure

1. Insert checking pin into wristpin hole. Place strips of paper between checking pin and crankcase cylinder gasket surface and apply slight downward

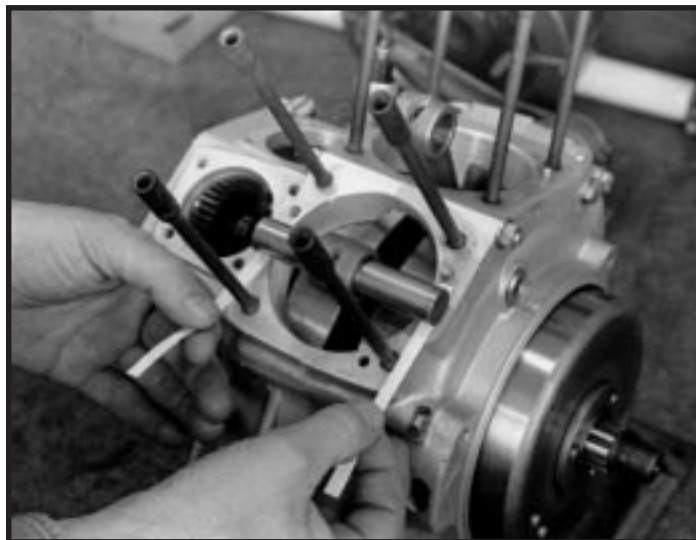

Picture 15

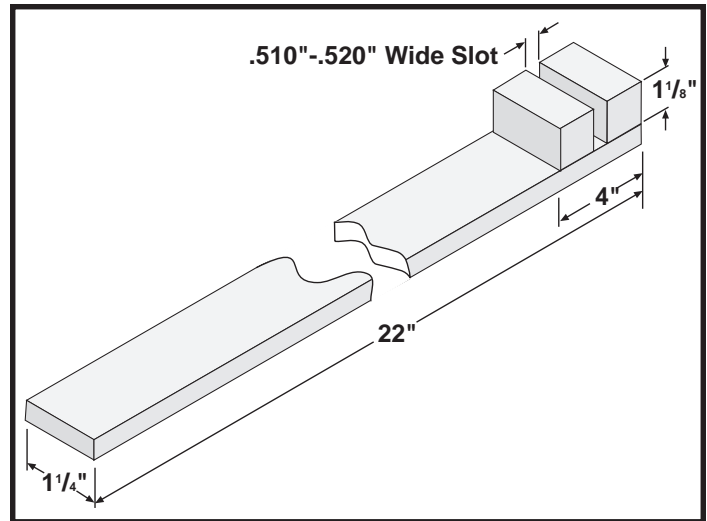

Figure 4

pressure to wristpin end of rod by rotating flywheels. Pull papers out slowly. Drag on papers should be equal. **See Picture 15.**

2. Rotate flywheels in opposite direction until checking pin contacts cylinder gasket surface again. Repeat procedure to rod again. If drag on papers is equal no bending is required. If one paper is loose, use rod bending tool to tweak rod in direction of loose paper and recheck.
3. Repeat checking and bending procedure for other rod.

C. Visual Procedure

1. Install pistons on rods without rings or wristpin clips. Bolt cylinders with gaskets in place.
2. Move piston tight towards camside of engine.
3. Turn engine over in normal direction of travel 2 or 3 revolutions and observe piston during process.
4. Move piston towards driveside of engine and repeat **Step C**. If inaccuracies are present

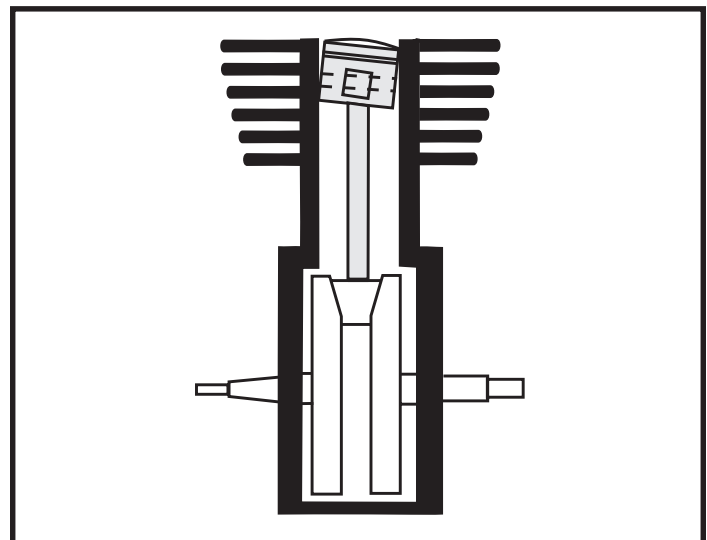

Figure 5

due to machining variations in cases, cylinders or pistons, top land of piston deck will appear closer to cylinder wall at one point around circumference. This means that piston is cocked in cylinder bore and can be corrected by bending rod in opposite direction. **Figure 5** shows an exaggerated side view of this condition.

5. Repeat **Steps B to D** for other cylinder.

11. Cylinder Head Preparation

- A. Head Gasket Surface Flatness Check - Before top end is assembled, head gasket to cylinder mating surfaces should be checked as follows
 1. Thoroughly clean cylinder head gasket surfaces.
 2. Place straight edge ruler across head gasket surface at different places around diameter to determine flatness.
 3. If unevenness is revealed, machine head gasket surface just enough to make complete contact.

CAUTION - Incomplete contact between gasket surfaces of cylinders and cylinder heads may cause combustion leakage possibly resulting in damage to cylinders and/or other engine components.

- B. Modify 883 Cylinder Head Combustion Chamber - If 883cc cylinder heads are to be used, the combustion chambers must be modified to improve air flow and reduce the compression ratio. Follow enclosed Instruction Sheet #3883 or #3884 depending on style of combustion chambers in heads to be used. 1200cc heads do not require this modification.

NOTE - Stock 1200cc heads or modified 883 heads will provide a usable compression ratio but the small valves and ports in stock heads will be a limiting factor for a large displacement performance motor. To achieve the full potential of the engine it is recommended that the size of the valves be increased and the ports modified to further improve flow. In weighing the expense and difficulty of these modifications, it may be more cost effective and results intensive to use S&S or other aftermarket performance heads.

12. Piston to Head & Piston to Valve Clearancing

NOTES

- The clearancing operations described in this section can be done simultaneously as the same set-ups are used. Please read this entire section before beginning work.
- All valve spring spacing, rocker arm to collar and rocker arm to rocker cover clearancing must be done before piston to valve clearancing can be checked.
- S&S flat topped pistons have sufficient valve clearance when used with most street high performance cams with lifts up to .525". However, we recommend that valve clearancing be checked if other than stock cam is used.

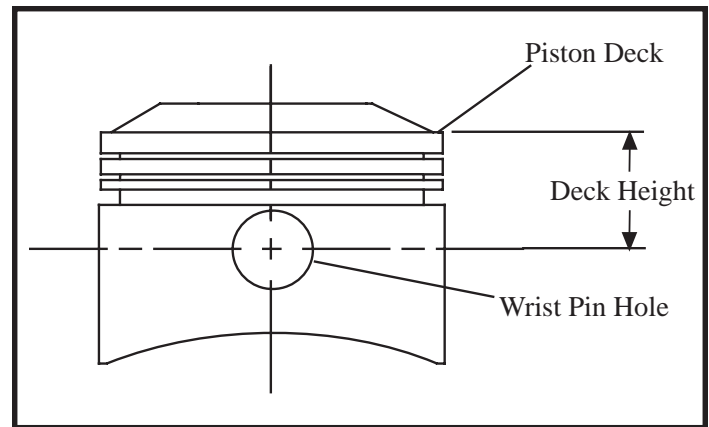

Figure 6

- If S&S cylinder heads and pistons are used, cams of up to .560" lift can be run without valve to piston clearance problems. If cams with higher lift are used this clearance must be checked.

CAUTION - Improper installation of pistons may cause unwarranted stress, premature wear and/or contact with each other or other engine components resulting in damage to pistons or other engine parts.

- If there is any resistance or contact at any point in rotation it must be diagnosed and corrected. Since it is nearly impossible to anticipate every possible engine combination, it is the engine builder's responsibility to check for proper running clearances. S&S considers checking and establishing all running clearances as standard engine building practice that must be performed during engine assembly. Engine failure due to improper clearances between moving parts is not covered under warranty.

CAUTION - Contact between moving engine components may cause damage or destruction of the parts involved and produce abrasive particles which may cause damage or premature wear to other engine components.

- A. Piston to head (squish) clearance
 1. Assemble engine with exception of cylinder heads.

NOTE - Pinion Shafts included in all S&S V² XL flywheels kits and assemblies are of the 1987 type. This means that 1986 crankcases must be converted to use the 1987 and later style caged roller pinion main bearing assembly, and that 1986-1987 style pinion gear and oil pump drive gears must be used in 1988 and later engines. See step 6.

2. Rotate flywheels so front piston is positioned at top dead center.
3. Note where piston deck (**See Figure 6**, piston deck diagram) is positioned in relationship to head gasket surface. Piston deck (flat located

just above top compression ring groove), not dome, must be flush with or slightly below gasket surface.

4. If piston deck is higher than cylinder at top dead center, something is wrong and S&S should be notified. If piston deck position is correct proceed to **Step B**.

NOTE - Most stock V² and S&S V² style engines are designed with .045" to .062" piston to head clearance. This clearance is provided by thickness of head gasket. Therefore at top dead center, piston deck should be flush with or slightly below head gasket surface of cylinder. Cylinder base gasket must be in place when this check is made.

CAUTION - Insufficient clearance between piston domes and cylinder heads will cause damage to pistons and heads.

B. Piston to Valve Clearance

1. Turn engine over until piston in front cylinder is at top dead center. Paint area around valve pockets on pistons with machinist's blue.
2. Place valves in cylinder head leaving off springs and retainers. Place head on cylinder and secure with one bolt.
3. Lower valves until they contact piston. Rotate valve marking painted area.
4. Remove head and check points of contact. Valve should fit in recessed area machined in piston dome.

NOTE - S&S recommends at least .060" clearance around periphery of valve.

5. If insufficient clearance exists, remove piston and grind valve pocket until head of valve fits flush with proper clearance. Clean parts thoroughly before reassembly.

CAUTION - Do not remove more material than needed when performing piston to valve clearancing. Removal of excessive amounts of material may weaken top ring land of piston causing piston breakage and serious engine damage.

6. Repeat procedure for other cylinder head.
7. Spread layer of putty into valve pockets in both pistons.
8. Assemble cylinder heads and bolt assemblies on cylinders with head gaskets in place. Install pushrods and adjust to simulate final assembly.

NOTE - If hydraulic lifters are used, pushrods should be adjusted so that lifters are completely collapsed for this test. This will insure that lifters do not collapse due to valve spring pressure, and that full valve lift is achieved.

9. Turn engine over in normal direction of travel two complete revolutions.
10. Remove cylinder heads and check thickness of putty in valve pockets.
11. If clearance is sufficient, disassemble top end and proceed to final assembly.
12. If less than .060" clearance in any area exists, remove piston from engine and grind area until proper clearance is achieved. Clean parts thoroughly before reassembly.

NOTE - S&S recommends at least .060" clearance between valve and piston valve pocket recess. While .060" clearance is recommended minimum, it is advisable to have more, if possible.

CAUTION - Insufficient clearance between piston and valves may cause them to contact each other during operation resulting in damage to piston and valve train components.

13. Final Assembly and Engine Installation

NOTE - Cleaning parts prior to and during assembly and keeping parts clean after final assembly are imperative to minimize contaminants that may circulate in oil and shorten engine life. Many parts can be cleaned with soap and water first. Then, reclean all internal parts and gasket mating surfaces using high quality solvent that does not leave any harmful residues. Be sure to read and follow manufacturer's instruction label before use. Use drills and compressed air to clean all oil passageways of dirt, filings, etc. whenever possible. During actual final assembly, recoat all internal parts with high quality engine oil or assembly lube such as S&S #51-9000.

CAUTION - Manufacturing chips, dirt and/or other contaminants circulating in engine oil may possibly damage engine components resulting in shorter engine life and possible engine failure.

WARNINGS

● Some solvents, degreasers and other chemicals are harmful to skin, eyes and other body parts. Many items are flammable and present a fire hazard. Read manufacturer's instruction label for proper use. Use in well ventilated area and wear protective clothing when using them to avoid personal injury.

● Compressed air and particles dislodged by compressed air are harmful to eyes and body. Wear protective goggles when using compressed air and always direct air stream away from body parts such as hands and eyes. Never direct compressed air toward other people.

- A. Spin each head bolt down on its respective stud to be sure threads are clean and free of contamination.
- B. Install cylinder base gaskets provided dry. Be sure gaskets match cylinder base line-up dowels and oil return passageways.

- C. Install pistons, rings and wristpin clips per S&S piston instruction sheet #2500.
- D. Coat piston skirts with engine oil or assembly lube and install cylinders.
- E. Place o-ring seals over cylinder head alignment dowels. Install head gaskets provided in kit dry.

NOTE - Care must be taken to use correct alignment dowel o-rings with V² head gaskets. Head gaskets supplied with S&S cylinder heads compress to about .045" thick and require .070" diameter o-rings. Gaskets supplied with SIDEWINDERS for stock heads compress to about .0625" and require .0825" diameter o-rings.

CAUTION - Using thin o-rings with thick gaskets or thick o-rings with thin gaskets may cause oil leaks or possible ruptured head gaskets around line-up dowels due to incorrect o-ring compression.

NOTE - All S&S cylinder head kits are supplied with .045" thick head gaskets, because this clearance promotes better combustion chamber turbulence and flame travel. When other cylinder heads are used S&S supplies .0625" thick gaskets. Using thicker head gaskets with S&S heads reduces design efficiency and performance. If thinner head gaskets are used with other cylinder heads, piston to head and valve to piston clearances must be checked during assembly.

CAUTION - Insufficient clearance between piston domes and cylinder heads or piston domes and valves will cause damage to pistons, heads and/or valves.

- F. Bolt heads on cylinders. Place one or two drops of oil on threads of each head bolt just prior to final assembly to reduce friction and insure accurate torque readings. Tighten bolts in

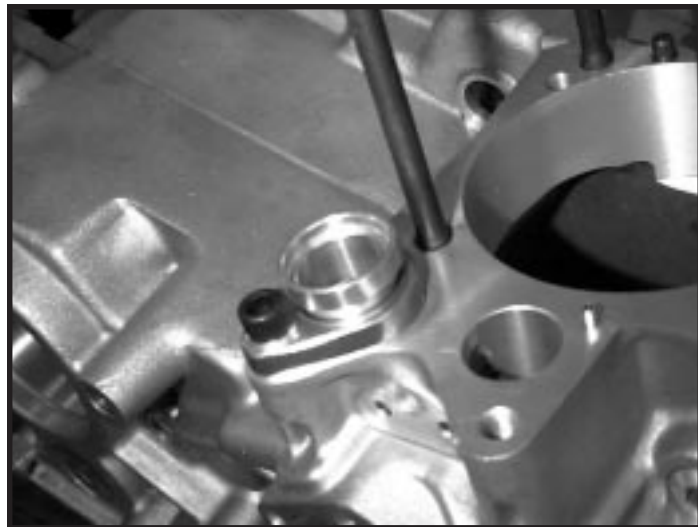

Picture 16

stages using crossing pattern. See **Figure 7**. If using S&S crankcases, torque bolts to 45-47 ft. lbs. in four stages. If using stock crankcases, follow the same bolt tightening sequence, but use stock three stage procedure and torque values shown in **Figure 7**. If using other aftermarket crankcases, contact the manufacturer for recommended head bolt torque specifications.

NOTE - Light coating of oil on head bolt threads minimizes friction so torque values are not distorted. It cannot be emphasized enough how important it is to do these steps carefully. Maintaining a good head gasket seal depends on it.

CAUTION - Improper torquing sequence and head bolt torque values may cause head gasket failure. Excessive torque values may cause studs to pull out of crankcase.

- G. Finish Assembling Top End
 1. Install rocker arm bases per H-D specs.
 2. 1991 And Later Five Speed Models Only - Stock one piece pushrod tube assemblies on 1991 and later five speed engines must be replaced with 1986 to 1990 style two piece pushrod tubes to allow adjustment of pushrods. Installation of #33-5360 S&S pushrod tube adapter provides cup for bottom of earlier style pushrod tubes. Place stock pushrod retainer over small end of adapter. Slide stock pushrod seal on small end of adapter. Install adapter, retainer, and seal over tappet bore in crankcase with stock bolt and washer. Do not final tighten. **See Picture 16.**
 3. Assemble rocker arms, pushrods and pushrod tube assemblies and adjust pushrods. For 1991 and later five speed motors, place bottom end of 1986 to 1990 style pushrod

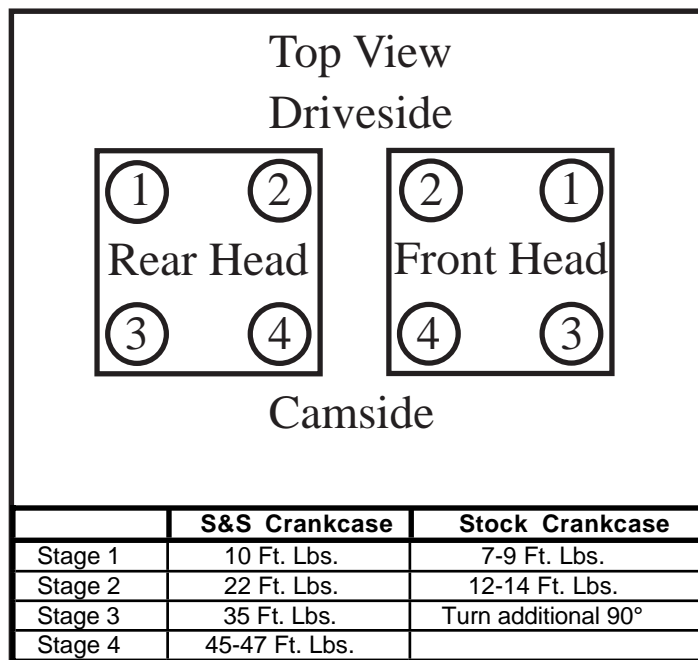

Figure 7

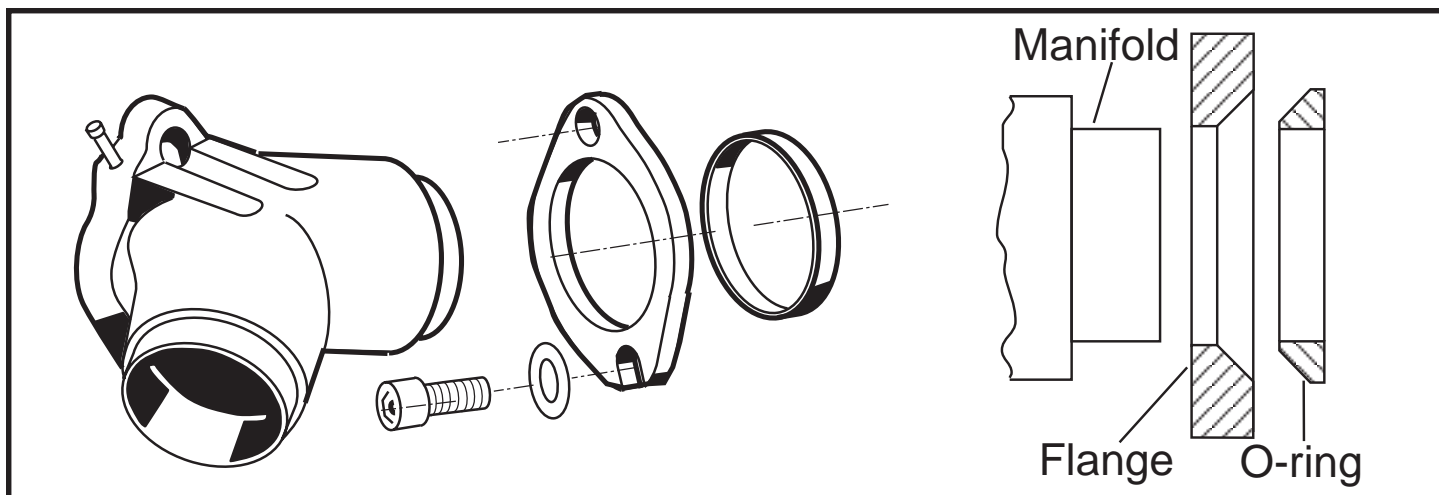

Figure 8

tubes in cup of adapter. Use stock 1986 to 1990 pushrod seals. Rotate S&S pushrod tube adapters so that cup surface is as close to perpendicular with pushrod tube as possible. Install pushrod cover clip and final tighten stock pushrod tube retainer bolt.

4. Install rocker covers and gaskets.
5. Install intake manifold, mounting flanges and o-ring seals. Be sure o-rings and flanges are assembled in correct sequence. Tapered side of o-ring must fit into tapered side of flange. **See Figure 8.** Use flange marked "F" on front head and flange marked "R" on rear. Slotted end of mounting flange goes toward lower manifold mounting hole. Flat washer provided is used on slotted end of flange. Do not tighten mounting flange screws.

NOTE - If S&S heads are installed, special S&S manifold must be used because intake port diameters of S&S heads are larger than stock. Special S&S manifold requires o-ring seals which also have larger than stock diameter to fit O.D. of manifold runners. These o-rings, S&S part #16-0235, are included and cannot be used in stock applications.

CAUTION - Incorrect o-ring seal may cause air leaks around manifold resulting in lean condition and possible damage to engine.

- H. Bolt carburetor and air cleaner assembly in place using carburetor instructions supplied from manufacturer. Final tighten manifold mounting flanges.

NOTE - Some builders may prefer to install carburetor after engine is installed in frame to reduce the possibility of damage to carb.

- I. Install engine in frame according to H-D factory procedures.

NOTE - The stock head mounts when used on Sportster V² Sidewinders with longer than stock cylinder lengths will be short. Use the special S&S head mounts provided.

- J. Reassemble gas tanks and all other parts that were disassembled during preparation for top end service. Be sure there are no gasoline leaks and that throttle opens and closes smoothly and snaps shut when released.

NOTES

- Throttle must not bind and must snap shut to fully closed position when released.
- Fuel needle and seat assembly must completely shut off fuel supply entering bowl. Fuel line connections must not leak.

CAUTION - Unwarranted gasoline leaking by fuel inlet needle may flood engine causing damage to components.

WARNINGS

- If throttle does not return to fully closed position when released, it may inadvertently stick open possibly causing loss of control of motorcycle and personal injury to you or others.
- Unwarranted gasoline leaks at fuel line connections and/or past inlet needle may flood engine and overflow on surrounding area creating fire hazard.

14. Engine Break-In Procedure

- A. Upon initial start-up, quickly check to make sure oil pressure is normal and no leaks exist. With minimal load on engine, ride motorcycle at low speeds until cylinder head temperature reaches about 250°. Do not crack throttle or subject engine to any heavy load during this period as V² head gaskets are susceptible to failure until heat build-up is completed. Heat build-up is necessary to cause heads and cylinders to expand and seal.

Improper initial engine start-up and break-in procedure may cause head gasket failure.

NOTE - Proper first time engine start-up and break-in is critical to achieve permanent and lasting head gasket seal. Prior to initial start-up, a .001" to .005" feeler gauge will fit between head gasket and head and cylinder gasket surfaces stopping at fire ring on head gasket. Warming engine as instructed will tightly close this gap producing a good, lasting seal.

CAUTION - Do not allow engine temperature to become excessive as permanent engine damage may result.

- B. First 50 miles are most critical for new rings and piston break-in. Most engine damage will initially occur during this period. Keep heat down by not exceeding 2500 rpm. Vary speed. Do not lug engine.
- C. Next 500 miles should be spent running engine no faster than 3500 rpm or about 50-55 mph. Do not lug engine and continue to vary speed.

CAUTION - Lugging or running engine prematurely at high rpm's may result in damage to pistons and/or other engine components. S&S voids its guarantee if engine is not broken in properly.

- D. For balance of first 1000 miles, speed can be run up to 60 to 70. Continue to run engine at all different speeds including lower 40-45 mph ranges.
- E. 1000 to 2000 miles—basically same procedures as before. You can be a little more liberal with rpm range. Avoid overheating engine and putting any hard strain on engine (drag racing, trailer towing, sidecar operation).
- G. 2000 miles and up—have fun!

15. Performance Notes

Ignition

● *Ignition system type - Most S&S engines initially tested on our dyno are equipped with a point type ignition system or an aftermarket high performance electronic unit. These systems allow us to bypass the performance parameters (such as the rpm limiter) designed for stock parts and built in to the stock ignition system. We use an other than stock system to establish some baseline comparisons and determine the maximum horsepower potential a given engine combination possesses. For "real world" evaluations and comparisons with stock combinations we will often use a stock electronic system with an H-D accessory performance ignition module, because more often than not this is what is already installed. Besides, since you already own it, the stock system is free and, under normal operating conditions, works very well with little or no maintenance - two requirements for satisfactory riding. We recommend a stock ignition system for most*

applications and the other systems for maximum efforts where getting every ounce of horsepower is more important than economizing. If the stock electronic system is retained, contact your local H-D dealer for the part number of an ignition module with specifications that coincide with your high performance requirements.

● *Spark plugs - Use spark plugs that are compatible with the ignition system. If you are in doubt, most manufacturers can recommend which plugs they prefer you use with their system. Dual plug installations in S&S Super Stock heads are not necessary.*

● *Flywheels - S&S flywheels for V² Sportsters have timing marks for front and rear cylinders. Both flywheels have timing marks to accommodate both four speed and five speed engines. The "F" mark is front cylinder 30° advanced (before TDC). The "R" mark is rear cylinder 30° advanced. When "F" or "R" timing marks are located in the center of the timing hole, the crankshaft is positioned 30° before TDC for that cylinder. Placing the mark to the rear of the hole, or just entering the hole, advances timing almost 5°. Conversely, if the mark is just leaving the hole, timing is retarded almost 5°.*

● *Timing - Tests conducted using S&S Super Stock heads and modified stock H-D heads showed that best performance was achieved with the ignition timing set between 30-32° before TDC. We attribute this to the higher compression ratios generally used, improved flow characteristics and improved overall efficiency. If using stock heads, the higher the compression ratio less advance is generally needed. Lower compression engines may require more advance. Some experimentation may be required to determine the best timing setting for best performance. Once the engine is timed and operating, monitor it for excessive heat. Too much heat can mean that timing is set incorrectly and should be adjusted to prevent engine damage.*

CAUTION - Improper ignition timing may cause excessive engine heat which may damage pistons and/or other engine components.

Carburetion

● *All S&S test engines are run using S&S carburetors. S&S Super E and G carburetors are recommended for most applications with the Super G being used more often on larger displacement, freer breathing engines with higher compression ratios. Typically, engines equipped with S&S heads require the same or slightly leaner jetting than those engines fitted with stock heads. Consult the carburetor jetting instructions for specific jetting recommendations.*

● *If another type carburetor is used, it must be made to run rich enough to operate properly and to prevent engine damage. If you have a problem with another carburetor, S&S cannot help you and recommends you call the carb manufacturer with any questions you may have.*

● *If the motorcycle is used exclusively on a drag strip where engine temperatures vary, slightly richer jets may be necessary for best performance. Larger jets/richer mixtures will enable one to run a colder engine which is sometimes desirable. This is best determined by experimentation.*

● *Carburetor jetting and spark plug color - While spark plug color may be used to help determine carburetor jetting, S&S recommends that our instructions be used as primary jetting guide and that plug color indications be used only as secondary aid. We have found that different brands of gasoline, gasoline additives, engine heat (due to ignition timing), and brands of plugs and heat range used distort plug color drastically making plug reading difficult for the average tuner. Also, new plugs usually require a road test of 10 miles or more to properly develop the color which means that quarter mile tests may not be long enough and hence, not always a good indication of carb jetting. It is best to use proven spark plug combinations and to consult the spark plug manufacturer if you have questions. If one desires to become more proficient at plug reading, Champion Racing Division has a very informative booklet which may be helpful. For details, write:*

*Champion Spark Plug Co.
PO Box 910
Toledo, OH 43601*

● *Cams and exhaust systems can make some engines difficult to carburate. We have found that certain cams and exhaust systems will cause poor performance at a specific rpm, and attempts to correct jetting for that specific level usually destroys carburetion over the balance of the range. A combination of cam overlap, reversion, and back pressure, or even lack of back pressure can cause mixture dilution at certain engine rpm's. This dilution will cause engine roughness or misfiring when engine is held in this range.*

Exhaust Systems

● *Drag pipes - While drag pipes can be used with good results to establish performance guidelines on pre-Evolution engines, they are generally not recommended for Evolution motors in street applications. Evolution engines are easier to carburate with muffled systems.*

● *Muffler systems - Most stock and many aftermarket exhaust systems are too restrictive and made exclusively for looks with little consideration given to performance. A very good, economical street system for V² engines consists of the stock header pipes with the crossover tube and a set of low restriction mufflers. Harley-Davidson*

offers a series of mufflers that can be used with stock header pipes that work very well in most situations and offer an inexpensive alternative to a new exhaust system. We prefer their tapered and baloney cut styles. This combination will typically produce 10 hp more than drag pipes in the midrange. Since the midrange is where the vast majority of normal driving occurs, it makes this system ideal for the street.

Gearing

● *Gearing depends on the total weight of the machine and rider's, the size of the engine, cams, exhaust system and type of riding to be done. Most high performance engines, and particularly those with larger displacements, are capable of pulling more gear. We suggest you break the engine in with stock gearing to minimize the load on the engine. After the engine is broken in you will have a better feel of its potential and can change gearing accordingly.*

● *For those who wish to determine their final drive gear ratio, refer to the formula shown below:*

Ratio is engine revolutions per one rear wheel revolution.

$$\text{Ratio} = \frac{(\text{Clutch Sprocket}^*) \times (\text{Rear Wheel Sprocket}^*)}{(\text{Motor Sprocket}^*) \times (\text{Transmission Sprocket}^*)}$$

*number of teeth on each sprocket

Compression

● *Generally speaking, Evolution engines with the proper camshaft selection can operate using higher compression ratios with fewer problems than their earlier counterparts. Keep in mind, though, that while engines with higher compression ratios make more horsepower and perform better, they also tend to lose that performance edge faster, require more maintenance and start harder. As a rule, we prefer to limit the compression ratio to no greater than about 10 to 1 for engine combinations used in normal street operation. A word of caution is in order. Before building an engine you may regret later on, carefully consider your riding needs, riding style and overall performance objectives.*